

# S3970RT

## ROUGH TERRAIN SCISSOR LIFT



- Diesel-powered rough terrain scissor lift
- Large work area with 1.2m roll-out deck extension
- Automatic self-levelling stabilisers
- Powerful 4x4 drive
- Ideal for construction applications

 **snorkel**  
[www.snorkellifts.com](http://www.snorkellifts.com)

# ROUGH TERRAIN SCISSOR LIFT

# S3970RT

## DIMENSIONS S3970RT

Max. working height	13.5m
Max. platform height (A)	11.5m
Platform size (stowed) (B)	2.73m x 1.65m
Platform size (extended) (C)	3.93m x 1.65m
Deck extension (D)	1.2m
Overall width (E)	1.8m
Overall length (F)	3.32m
Stowed height (G)	2.95m
Min. height (guardrails folded)	2.15m
Ground clearance	350mm

## PERFORMANCE

Platform capacity (SWL)	350kg
Max. drive height	11.5m
Max. drive speed (stowed)	4.5km/h
Max. drive speed (elevated)	0.35km/h
Raise/lower time	48/54 sec
Gradeability	30%
Max. outrigger levelling, front to rear	7°
Max. outrigger levelling, side to side	11°
Inside turning radius	2.38m
Outside turning radius	4.75m
Tyres	27 x 10.5 x 15 poly-filled loader lug
Controls	proportional joystick
Drive system	4 wheel drive

## POWER

Power source	Kubota diesel engine
Power options	Gasoline, LPG, Combination (LPG/Gasoline), Bi-Energy 24V DC

## WEIGHT

Gross weight	3,790kg
--------------	---------

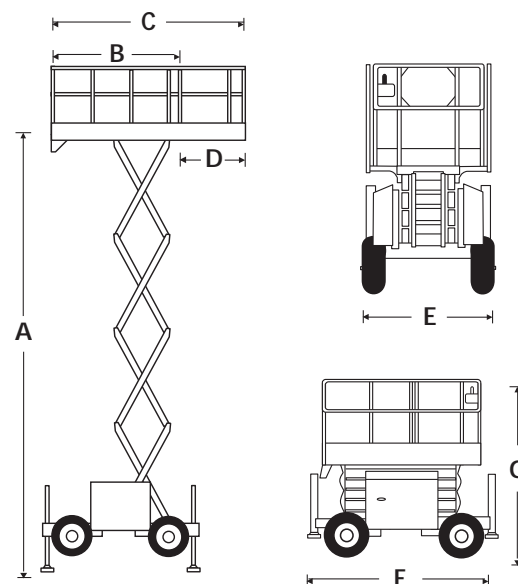

## STANDARD FEATURES

- Proportional joystick controls
- 1.2m roll-out deck extension
- Diesel engine
- 4 wheel drive
- Driveable at full height
- Hour meter
- Automatic self-levelling stabilisers
- Independent articulating rear axle
- Forklift pockets
- Lifting lugs and tie down rings
- Flashing amber light

## OPTIONS

- No stabilisers
- Non-marking tyres
- 110/240V power to platform
- RCD/ELCB outlet

## TURNING RADIUS

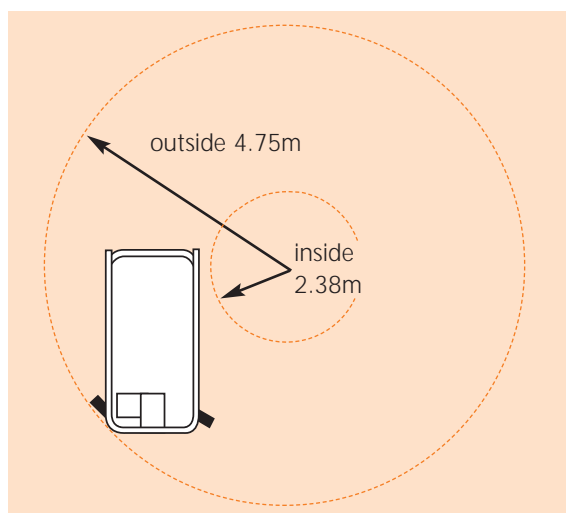

**snorkel** [www.snorkellifts.com](http://www.snorkellifts.com)

2/26 Redfern Street,  
Wetherill Park,  
NSW 2164, Australia  
t: +61 1300 900 700  
e: sales.au@snorkellifts.com