

AMMANN

YR® YOUNG/MAN
RICHARDSON
& CO. LTD.



Machines

ARX Tandem Rollers 1.5 - 4.5 t

www.ammann-group.com

ARX 12 - 45 Vibrating Rollers

Compaction Power pure

3 Platforms - 8 Models - 13 Versions

The lightest platform from 1.4 to 1.6 tonnes operating weight and working widths from 82 to 100 cm offers 3 models for small job sites of asphalt or gravel layer compaction.

Specific focus for the most common size of small tandem rollers was assured having a separate platform for the ARX23 and ARX26 (weight class 2.3 - 2.6t, working widths 100 and 120 cm). This results in the best Quality - Performance - Cost ratio on the market.

Type	CECE-weight	Drum width	Compaction
	kg	mm	kN
ARX12	1475	820	23
ARX16	1520	900	23
ARX16 K	1460	900	23
ARX20	1570	1000	24
ARX23	2250	1000	41
ARX23 K	2150	1000	41
ARX26	2460	1200	47
ARX26 K	2230	1200	47
ARX36	3740	1300	50
ARX40	4125	1300	52
ARX40 K	3840	1300	52
ARX45	4670	1380	55
ARX45 K	4070	1380	55



ARX 12 / 16 / 20 „side-free version“ & ARX 23 / 26 / 36 / 40 / 45



One Concept - 13 models

Compaction Power pure



Best compaction performance

By combining the ARX36, 40 and 45 in the heaviest platform Ammann is able to generate outstanding compaction output for medium asphalt jobs and base courses of gravel, sand and mixed soils.

The large drum diameter of these models offers the best compaction factor in the market.







ARX1 - Complete side-free



ARX2-4 - drum offset



Combination Version

Tandem Version

The ARX-range with 8 models of double-drum roller in the weight categories 1.5 – 4.5 tonnes and working widths from 820 – 1380 are designed for asphalt- and soil compaction.

All models have an optimum design with regard to use and economic efficiency based on three product categories. A new hydraulic concept coupled with the latest Yanmar diesel engine technology enable us to gain a significant increase in efficiency. It allows the diesel engine to run at a much lower speed, effectively reducing consumption and noise emissions.

A generously designed operator station with vibration insulation, a simple and clearly laid out operating panel and the multi-functional drive lever next to a comfort-seat form a unit that any driver will welcome for ergonomic reasons and more.

Combination Version

The ARX-rollers are also available as combination rollers ARX16 K, 23K, 26K, 40K and 45K.

The combination model has an in-built anti-adhesive tank with direct pressurised sprinkler system to the tyres. The control of the anti-adhesive sprinklers is operated by a separate hand switch. The standard interval-sprinkler switch allows optimum water-supply on every asphalt-job.

Side-free Model

The ARX12 - 20 tandem vibrating rollers are supplied as full flush models with double drive and double vibration as standard. This feature enables the drum to compact completely up against a wall. There is no more additional tuning work needed with additional compaction equipment.



40 mm off-set of drums





ARX Vibrating Rollers - One Concept

Features & benefits



The operator makes the difference

During the development of the ARX series the needs of the operator were at the centre of the platform design. Our standard ergonomic criteria to design a safe, comfortable and productive working environment are:

- Double vibration isolated operator platform
- Fully adjustable and lateral sliding seat
- „Best - View - Design“ to drum edges and surfaces by narrow frame structure
- Clear, simple and robust layout of all displays, switches and clashboard

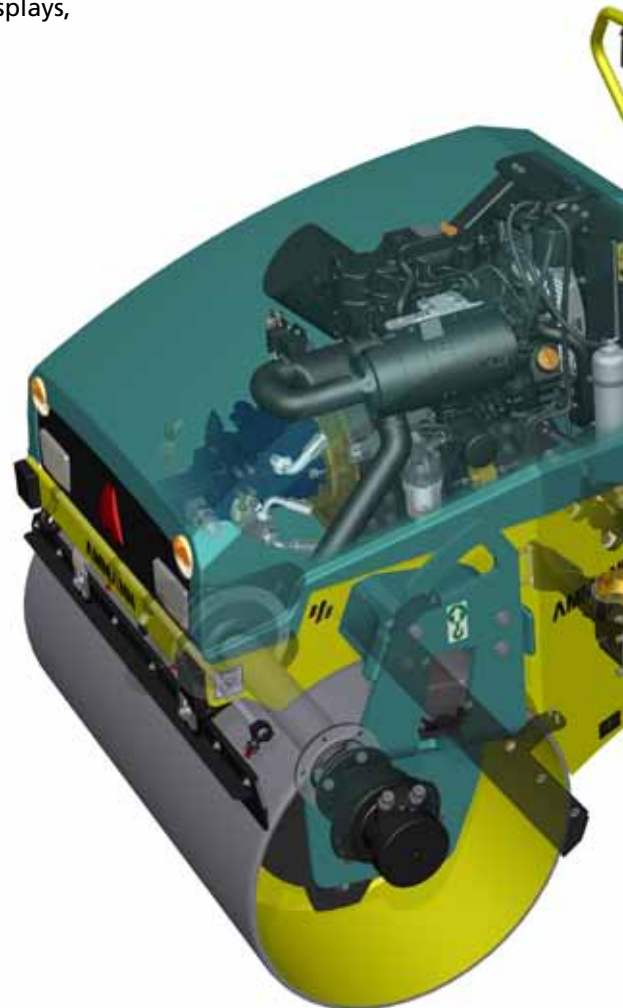

Best view to drum



Technic - Safety - Comfort

Features & benefits



Vibration & Sprinkler System

- Strong vibration system with 2 frequencies
- Large drum diameter for excellent asphalt compaction
- Large water tank for minimum of 1 days usage
- Water-sprinkler-system with pressurized pump; interval timer and 3 stage filtration
- AVC - Ammann Vibration Control
- 2 vibration amplitudes for ARX36, 40, 45

Driver comfort and safety

- Highest levels of driver comfort due to:
 - Rubber-mounted driver's platform isolated from chassis
 - Adjustable seat
 - Slideable seat (ARX23-45)
- Emergency - switch standard

Transport

- Folding ROPS for best transportation
- 4 Large towing-hooks front rear
- Central lifting-point on ARX12-26

Emission & Consumption

- Latest Yanmar diesel engine technology for the lowest fuel consumption and emission level
- Biodegradable oil is an option

Service

- Due to the large opening engine hood optimum access from one side for daily service checks.
- Maintenance-free articulation-joint
 - = no greasing for lifetime of the machine
- Simple and reliable electrical circuits with relays instead of printed circuit boards



Easy operation and safe transport



Clear dashboard layout



4 large tie down points for safe fixing onto trailer / truck



Best service access due to large engine hood



Central lifting point on ARX1(standard) ARX2(option)



Powerful

Optimum compaction results thanks to:

- High-torque, water-cooled Yanmar diesel engine
- 2 working speeds
- 2 frequencies with 2 centrifugal forces
- Single or double vibration with double traction
- Large drum diameter
- Balanced weight front and rear
- Large corrosion free water tank
- Multiple water filtration
- 2 scrapers per drum

Easy to operate

High comfort of operation due to:

- Easy-to-operate instrument panel
- Tight turning radius
- Compact dimensions for transport
- Smooth starting and reversing of the machine by electric drive-lever
- Rubber mounted operator's platform

Easy to maintain

Minimum maintenance required:

- Bearings are lubricated for life time
- Teflon-coated central articulation-joint; lubricated for lifetime
- Engine hood can be completely opened
- Direct access to the maintenance points situated at one side
- Outside drain plugs for rapid change of machine fluids
- Water filters and nozzles are easily accessible

Safe

High safety standards

- CE-Package: Folding ROPS, emergency stop, comfort seat with security belt and seat contact switch
- Ergonomic instrument panel
- Unobstructed view to the drums

Vandal protection of the machine with lock preparation on:

- instrument panel
- engine hood
- fuel tank
- water tanks

Suitable

The ARX-Serie rollers are based on a modular concept allowing

- the customisation of the machine to specific applications of the user
- optimisation of spare parts management due to wide compatibility of the parts between different ARX models





Lockable diesel-tank standard

Folding ROPS for easy transport

2 drive-lever

Edge-cutter

Standard

- Front and rear vibration and drive
- Control system with emergency stop
- Pressurised plus intervall sprinkler system
- Ammann Vibration Control
- Lateral sliding seat on ARX23 - 45
- Central lifting hook (option on ARX 2)
- 2 working frequencies
- Hydraulic test-port

Options

- CE-Kit with folding ROPS and working lights
- Road lighting
- Canopy
- Asphalt-thermometer (only on ARX4)
- Reverse alarm
- Battery disconnection switch
- Central lifting hook (only on ARX 2)
- Wide-tyre-kit ARX 26 combi
- ATC - Ammann Traction Control (only on ARX 2 + 4)
- Arm rests
- second drive-lever, left
- Edge-cutter incl. multi-function lever
- Bio-degradable hydraulic oil
- Drums in Line (only on ARX 1)
- Customer Colour

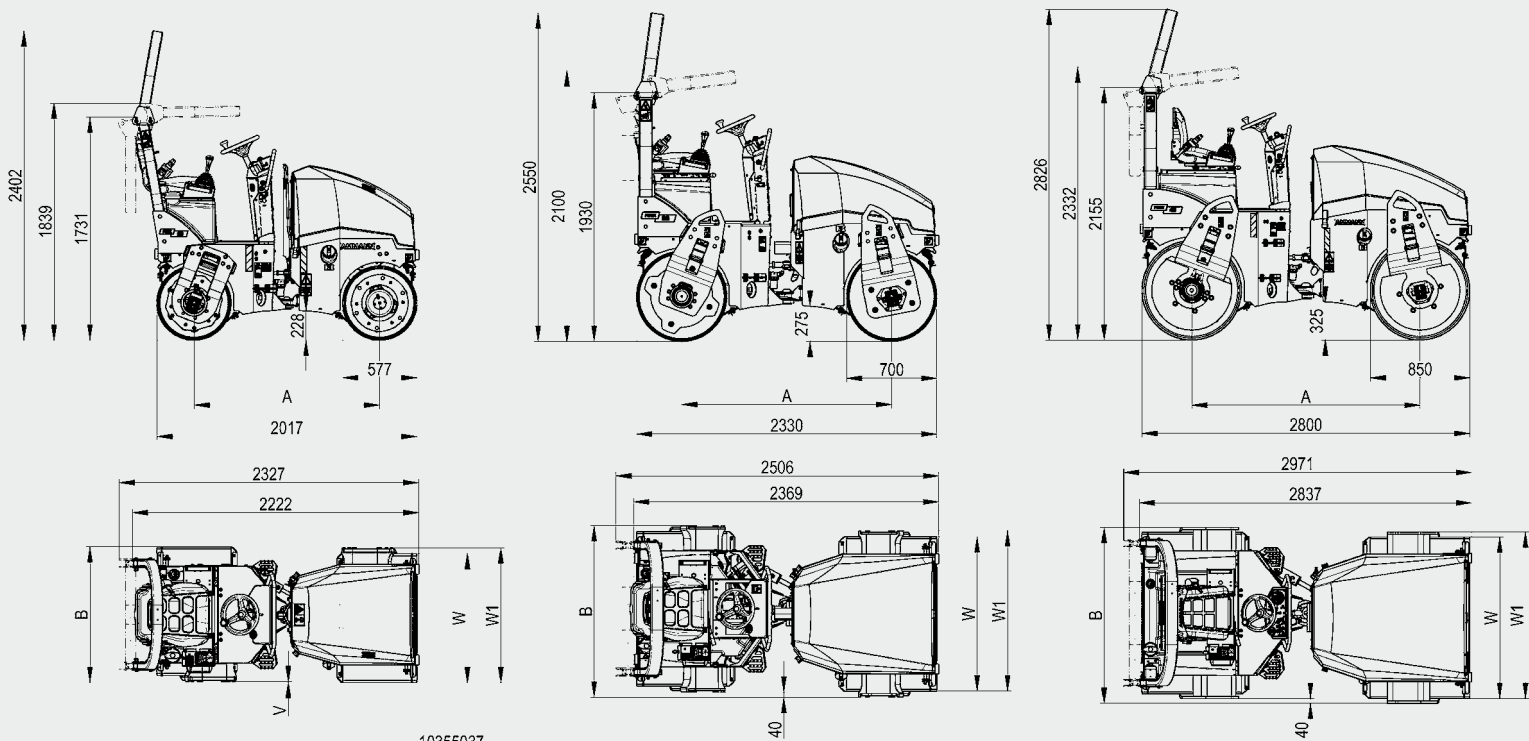

10355037 -

10338852 -

10370920 -

	ARX12	ARX16	ARX16K	ARX20	ARX23	ARX26	ARX23K	ARX26K	ARX36	ARX40	ARX45	ARX40K	ARX45K
A	1440	1440	1475	1440	1630	1630	1653	1653	1950	1950	1950	2008	2008
B	874	952	947	1054	1129	1334	1089	1294	1423	1423	1503	1463	1463
W	820	900	900	1000	995	1200	995	1200	1300	1300	1380	1300	1380
W1	865	947	947	1046	1042	1247	1042	1247	1341	1341	1421	1341	1421
V	9	5	-	8	-	-	-	-	-	-	-	-	-

Dimensions in mm



Technical Data and Specifications

ARX Series

		ARX 12	ARX 16	ARX16 K	ARX20	ARX 23	ARX 23 K	ARX 26	ARX 26 K	ARX 36	ARX 40	ARX 40 K	ARX 45	ARX 45 K	
Weight															
Operating weight CECE	kg	1475	1520	1460	1570	2250	2150	2460	2230	3740	4125	3840	4670	4070	
Operating weight max.	kg	1700	1700	1700	1700	2450	2450	2650	2650	4300	4700	4700	5100	5100	
Static linear load (full-flush)	kg/cm	9	8,4	8,4	7,9	11,3	11,3	10,3	10,3	14,4	15,8	15,8	16,9	16,9	
Wheel load	kg	-	-	183	-	-	251	-	260	-	-	480	-	508	
French classification		PV2	PV2	PV2	PV2	PV3	PV3	PV3	PV3	PV3	PV4	PV4	PV4	PV4	
Drums (Wheels)															
Width	mm	820	900	900	1000	1000	1000	1200	1200	1300	1300	1300	1380	1380	
Offset	mm	50	50	0	50	40	0	40	0	40	40	-	40	-	
Rolling width max.	mm	870	950	900	1050	1040	1000	1240	1200	1340	1340	1300	1420	1380	
Diameter mm	mm	575	575	575	575	700	700	700	700	850	850	850	850	850	
Thickness mm	mm	13	13	13	13	13	13	13	13	17	17	17	17	17	
Number of wheels		-	-	4	-	-	4	-	4	-	-	4	-	4	
Tire size		-	-	8/60-15	-	-	8/60-15	-	8/60-15	-	-	10.5/80-16	-	10.5/80-16	
Tire-axle width	mm	-	-	890	-	-	970	-	1170	-	-	1275	-	1275	
Motor															
Engine and type	Diesel/Water	YANMAR 3TNV76				YANMAR 3TNV88				YANMAR 4TNV88					
Emmission class		--- / EPA 4				EuroMot3A / EPA Inter 4				Euromot3A - EPA Inter 4					
Power output ISO 3046	kW / HP	15.0/20.4				22.5/30.6				30.0/40.8					
Cylinder/ltr.	No./ccm	3 cyl / 1116				3 cyl / 1642				4 cyl / 2189					
1. /2. working speed	rpm	2.100 / 2.400				2.100 / 2.400				2.100 / 2.400					
Travel speed km/h	km/h	0 - 8				0 - 10				0 - 10					
Gradeability with / without vibr.	%	30 / 40				30 / 40				30 / 40					
Electric System															
Batterie / Capacity	V / Ah	12 / 77				12 / 77				12 / 77					
Steering															
Turning radius inside	mm	2165	2125	2125	2075	2350	2250	2250	2250	2581	2581	2621	2581	2621	
Steering / Oscillating angle	+/-°	31/5	31/5	31/5	31/5	32/8	32/8	32/8	32/8	32/8	32/8	32/8	32/8	32/8	
Vibration															
Amplitude	mm	0,5	0,5	0,5	0,45	0,42	0,45	0,42	0,45	0,36 / 0,55	0,36 / 0,55	0,34 / 0,55	0,36 / 0,55	0,34 / 0,55	
Frequency at 2100/2400 rpm	Hz	58 / 66	58 / 66	58 / 66	58 / 66	58 / 66	58 / 66	58 / 66	58 / 66	45 / 57	45 / 57	45 / 57	45 / 57	45 / 57	
Centrifugal force - max.	kN	23	23	23	24	41	41	47	47	50	52	52	55	55	
Capacities															
Water tank	ltr	110	110	110	110	200	200	200	200	350	350	350	350	350	
Anti-adhesive	ltr	-	-	10	-	-	12	-	12	-	-	-	-	18	
Hydraulic tank	ltr	16	16	16	16	16	16	16	16	37	37	37	37	37	
Diesel fuel tank	ltr	26	26	26	26	40	40	40	40	59	59	59	59	59	

Technical data subject to changes



6 - 10 Parkway Drive, Mairangi Bay, Auckland 0632
Ph: 09 443 2436 Auck Ph: 03 341 6923 Chch

www.yrco.co.nz

Ammann distribution companies:

Germany:

Ammann Verdichtung GmbH
D-53773 Hennef
Tel +49 22 42 880 20
Fax +49 22 42 88 02 59
info.avd@ammann-group.com

France:

Ammann France SAS
F-94046 Créteil/Cedex
Tel +33 1 45 17 08 88
Fax +33 1 45 17 08 90
info.afr@ammann-group.com

United Kingdom:

Ammann Equipment Ltd.
Bearley Stratford upon Avon
GB-Warwickshire, CV37 8XY
Tel +44 1789 414 525
Fax +44 1789 414 495
info.ael@ammann-group.com

USA:

Ammann America Inc.
Ponte Vedra, Florida 32082, USA
Tel +1 904 543 1691
Fax +1 888 266 1210
info@ammann-america.com

Poland:

Ammann Polska sp.z.o.o.
02-230 Warszawa
Tel +48 22 33 77 900
Fax +48 22 33 77 929
info.aep@ammann-group.com

Russia:

Ammann Russland o.o.o.
RU-129343 Moskau
Tel +7 495 933 35 61
Fax +7 495 933 35 67
info.aru@ammann-group.com

Ammann manufacturing companies:

Switzerland:

Ammann Schweiz AG
CH-4901 Langenthal
Tel +41 62 916 61 61
Fax +41 62 916 64 03
info.aag@ammann-group.com

Germany:

Ammann Verdichtung GmbH
D-53773 Hennef
Tel +49 22 42 880 20
Fax +49 22 42 88 02 59
info.avd@ammann-group.com

Czech Republic:

Ammann Czech Republic a.s.
CZ-54901 Nové M sto nad Metují
Tel +420 491 476 111
Fax +420 491 470 405
info.acz@ammann-group.com



International Distribution Partners: www.ammann-group.com