

Specifications

MODEL	GH [®] -3.8		GH-5.6	
Measurements	Metric	US	Metric	US
Height - stowed	1.04 m	3 ft 5 in	1.37 m	4 ft 6 in
A - lifting height	3.80 m	12 ft 5.6 in	5.60 m	18 ft 4.5 in
B Length - platform	0.48 m	1 ft 7 in	0.48 m	1 ft 7 in
C Width - platform	0.61 m	2 ft	0.61 m	2 ft
D - base (corner to corner)	1.35 m	4 ft 5 in	1.35 m	4 ft 5 in
Productivity				
Load capacity	136 kg	300 lbs	113 kg	250 lbs
Storage/transport dimensions	0.36 x 0.36 x 1.00 m	14 x 14 x 39.5 in	0.36 x 0.36 x 1.00 m	14 x 14 x 39.5 in
Power				
Recommended PSI	5.86 bar	85 psi	5.86 bar	85 psi
Weight*				
	34 kg	75 lbs	37 kg	82 lbs

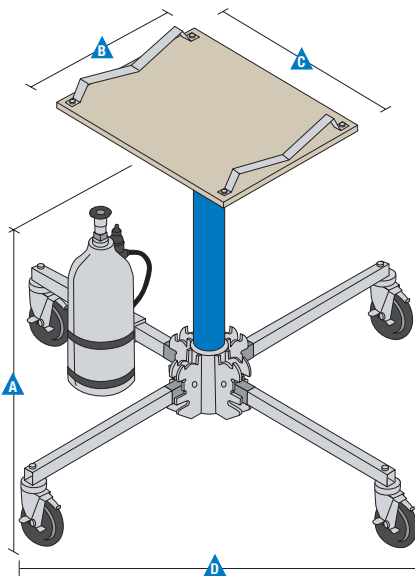

* Weight will vary depending on options and/or country standards.

Features

Standard Features

Measurements

GH™-3.8

- 3.80 m (12 ft 5.6 in) lifting height
- 136 kg (300 lbs) load capacity

GH-5.6

- 5.60 m (18 ft 4.5 in) lifting height
- 113 kg (250 lbs) load capacity

Productivity

- One-piece platform
- Portable and compact design
- Up and down dump valve can be easily activated by patented control handle
- The Super Hoist sets up in seconds — no tools required
- The one-piece platform attaches to cylinder with a twist of the wrist
- Legs fold up for easy storage
- Easy-to-release leg lock keeps legs up for storage and out for use
- Wheel brakes
- Auto-lubricating oil reservoir on top of each piston inside the cylinder
- Easy to service

Power

- Powered by CO₂ or compressed air
- One size fits all CO₂ bottle mounting bracket

Options & Accessories

Productivity

- Platform cradle package



AUCKLAND HEAD OFFICE

6-10 Parkway Drive,
Mairangi Bay, Auckland
Phone: (+64) 09 443 2436
Fax: (+64) 09 443 2435
Email: sales@yrco.co.nz

SOUTH ISLAND OFFICE

20 Nga Mahi Road,
Sockburn, Christchurch
Phone: (+64) 03 341 6923
Fax: (+64) 03 341 6955
Email: saleschch@yrco.co.nz



PROUD TO BE 100%
NEW ZEALAND
OWNED & OPERATED

YR® YOUNG/MAN
RICHARDSON
& CO. LTD.