



www.quickaccess.com.au



Raptor

MV095J



Toll Free - 1800 MASSIVE

www.quickaccess.com.au

SELF-PROPELLED MAST LIFT

Raptor

MV095J

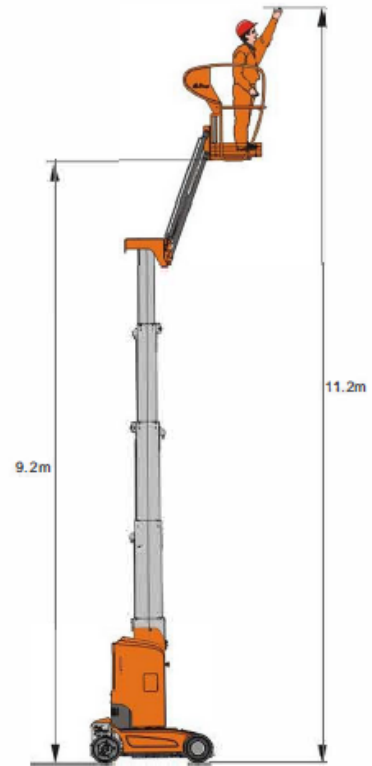
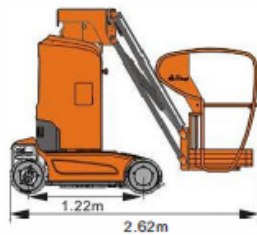

S.W.L	200kg
Max.occupants	2



Working height	11.20m
Platform floor height	9.20m

Horizontal outreach	3.00m
Up and over height	7.89m
Overall length	2.62m
Overall width	1.00m
Overall height	1.99m
Platform size	0.62x0.87m
Ground clearance(Stowed)	0.075m
Ground clearance(Raised)	1.019m
Wheelbase	1.22m
Turning radius	1.80m



Turret rotation	345°
Jib movement	+70°/-60°



Drive motors	24V/1.5kw
Lifting motors	24V/3kw



Travel speed(Stowed)	4.5km/h
Travel speed(Raised)	0.5km/h
Up/Down speed	95/50 sec



Batteries	24V/240Ah
Integrated charger	24V/30A

Please Note:-
All information contained in this publication was correct at time of printing but may be subject to change without notice.



Gradeability	25%
Maximum slope	2.5°



Tyres	φ 381x127mm
--------------	-------------



Weight	2950kg
---------------	--------

Standard Equipment

- Proportional Controls
- Automatic Pothole Protection
- Self Close Gate On Platform
- Drivable At Full Height
- Platform Horizontal Outreach
- Non-marking Tyres
- 2WD
- Automatic Brake System
- Emergency Lowering System
- Emergency Stop Button
- Cylinder Holding Valve
- Onboard Diagnostic System
- Tilt Sensor With Alarm
- All Motion Alarm
- Horn
- Hour Meter
- Charger Protection
- Flashing Beacon
- Swing Out Components Cover
- 345° Turret Rotation
- Overload Sensor With Alarm

Options

- AC Power To Platform
- Platform Work Lights
- Airline To Platform



QUICK ACCESS

VICTORIA - 10-12 Industry Park Dr Brooklyn VIC 3012

NSW - 3/192 Wisemans Ferry Road Somersby NSW 2250

www.quickaccess.com.au

Toll Free - 1800 MASSIVE